

PLAN

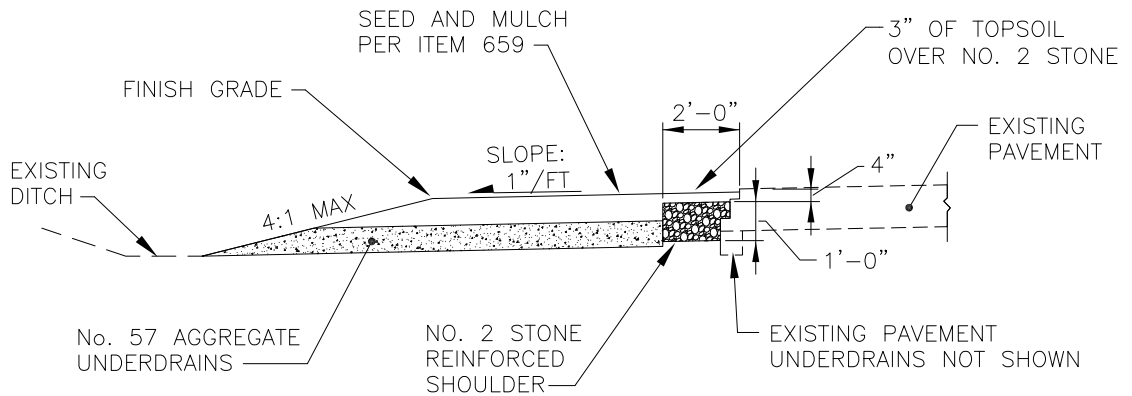

SECTION A

NOTES:

- ON EXISTING ROADS, AGGREGATE UNDERDRAINS SHALL BE LOCATED AT BEGINNING, ENDING, AND HALFWAY POINT ALONG THE RADIUS, AND AT 50' (MAX.) INTERVALS ALONG STRAIGHT PORTION OF THE ROAD.
- WHEN REINFORCED SHOULDERS ARE BEING CONSTRUCTED AS A PART OF NEW ROADS, PIPE UNDERDRAINS SHALL BE USED PER STANDARD DRAWING DCED-R2135.
- THE CONTRACTOR SHALL MAINTAIN ALL EXISTING DRAINAGE PIPES, TILES AND ROADWAY UNDERDRAINS ENCOUNTERED IN THE FIELD AND, IF DAMAGED, SHALL REPAIR OR REPLACE THEM IMMEDIATELY WITH THE SAME SIZE AND QUANTITY OF MATERIAL FOUND.

CHRIS E. BAUSERMAN, P.E., P.S.
Delaware County Engineer

Delaware County Engineer

STANDARD CONSTRUCTION DRAWING
REINFORCED SHOULDER
(FOR OPEN DITCH ROADS)

DELAWARE COUNTY ENGINEER'S OFFICE
50 Channing Street
Delaware, Ohio 43015
PHONE: (740)833-2400 FAX: (740)833-2399
www.co.delaware.oh.us

APPROVED
1-22-2008

REVISED
1-04-2010

Drawn <u>MR</u>	sheet <u>1</u>	FILE NO.
Checked <u>EM</u>	of <u>1</u>	DCED-R2137