

NOTE: A LARGER RADIUS MAY BE REQUIRED PER CURRENT COUNTY STANDARDS. RADIUS MUST BE APPROVED BY COUNTY ENGINEER.

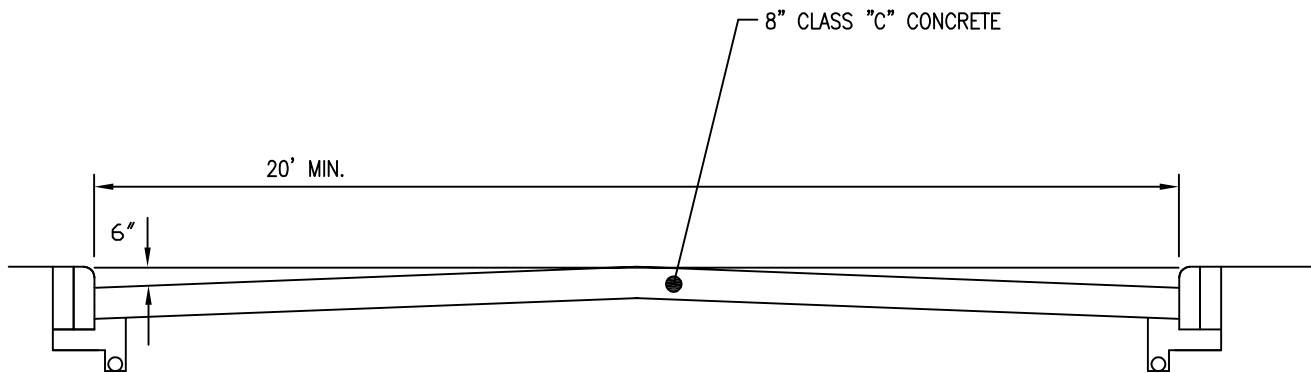

SECTION A-A  
THROUGH CROWNED PAVEMENT

THE CONTRACTOR SHALL BE RESPONSIBLE FOR COORDINATING ALL INSPECTIONS FOR THE CONSTRUCTION OF THE DRIVEWAY WITH THE COUNTY INSPECTION DEPARTMENT AT 740-833-2400.

FOR ADDITIONAL NOTES AND SPECIFICATIONS, SEE STD. DRAWING DCED-R2300. FOR JOINT DETAIL, SEE STD. DRAWING DCED-R2170.

<b>CHRIS E. BAUSERMAN, P.E., P.S.</b> Delaware County Engineer		STANDARD CONSTRUCTION DRAWING  <b>COMMERCIAL DRIVE          APPROACH          CURB &amp; GUTTER</b>		<b>DELAWARE COUNTY ENGINEER'S OFFICE</b> 50 Channing Street Delaware, Ohio 43015 PHONE: (740)833-2400 FAX: (740)833-2399 www.co.delaware.oh.us	
APPROVED 1-22-2008	REVISED 11-10-2014	Drawn <u>KS</u> Checked <u>EM</u>	sheet <u>1</u> of <u>1</u>	FILE NO. DCED-R2203A	