

FOR ALIGNMENTS OR ORIENTATIONS OTHER THAN 90°, THE SPECIFIC ORIENTATION MUST BE APPROVED BY THE DELAWARE COUNTY ENGINEER'S OFFICE.

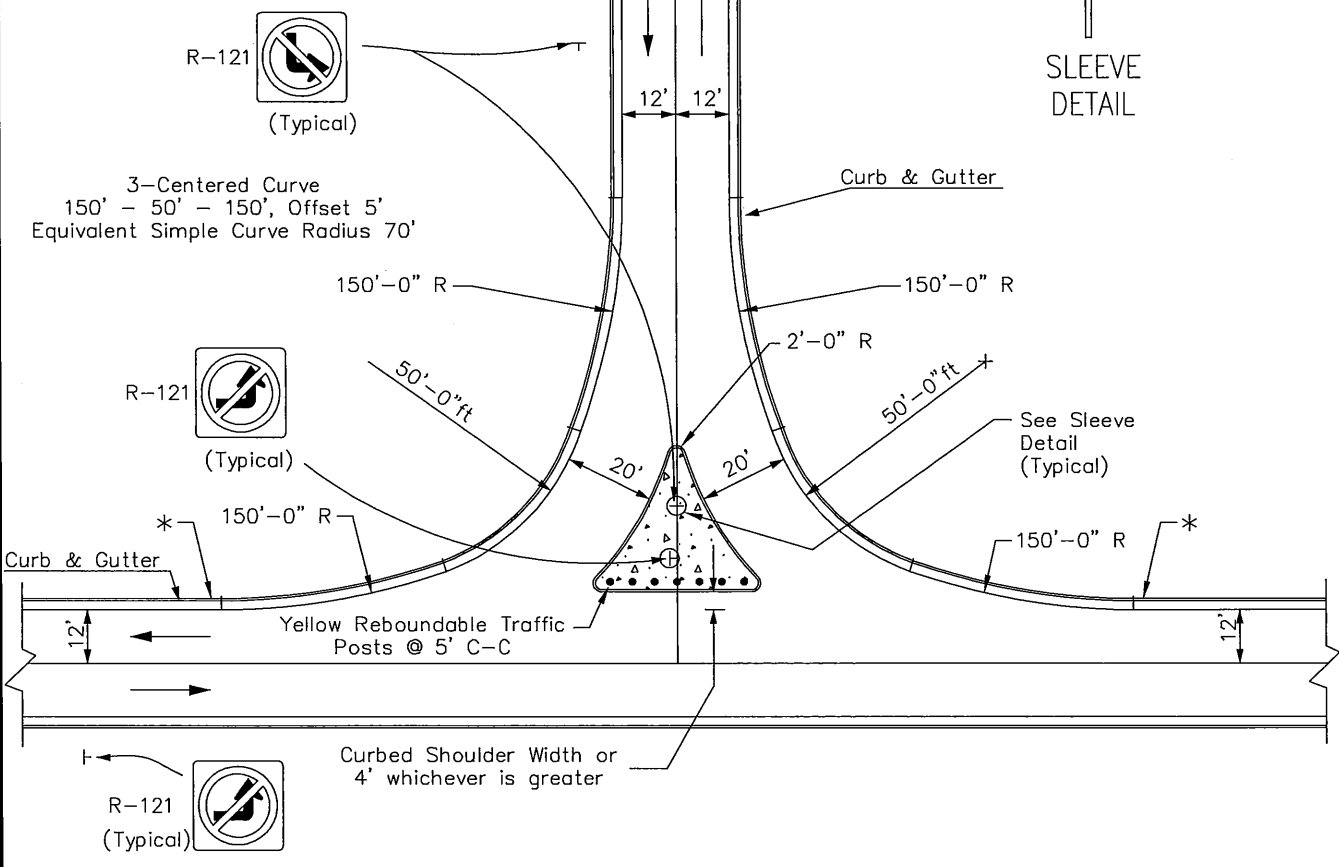
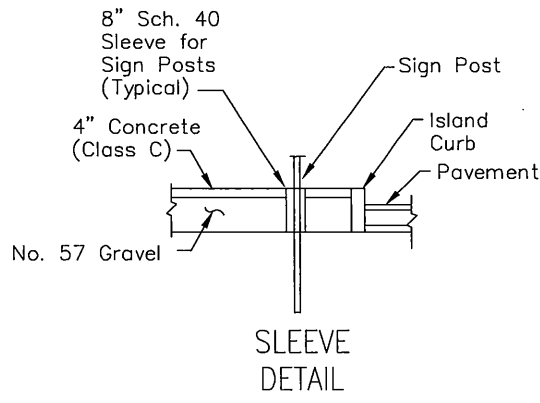
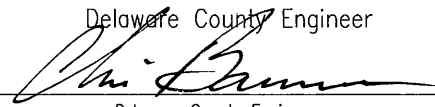

URBAN (CURBED) - RIGHT IN/RIGHT OUT WITHOUT RIGHT TURN LANE

* ON EXISTING CURBED ROADS, SAWCUT AND REMOVE PORTION OF EXISTING CURB AND GUTTER AS NECESSARY TO PROVIDE A SMOOTH TRANSITION FROM THE PROPOSED DRIVE CURB TIE-INTO THE EXISTING CURB AND GUTTER.

<p>CHRIS E. BAUSERMAN, P.E., P.S. Delaware County Engineer</p>  <p>Delaware County Engineer</p>	<p>STANDARD CONSTRUCTION DRAWING</p> <p>RIGHT IN/RIGHT OUT</p>	<p>DELAWARE COUNTY ENGINEER'S OFFICE 50 Channing Street Delaware, Ohio 43015 PHONE: (740)833-2400 FAX: (740)833-2399 www.co.delaware.oh.us</p>					
<p>APPROVED 1-04-2010</p>	<p>REVISED</p>	<table border="1"> <tr> <td>Drawn EM</td> <td>sheet 1</td> <td rowspan="2">FILE NO. DCED-R2450A</td> </tr> <tr> <td>Checked EM</td> <td>of 2</td> </tr> </table>	Drawn EM	sheet 1	FILE NO. DCED-R2450A	Checked EM	of 2
Drawn EM	sheet 1	FILE NO. DCED-R2450A					
Checked EM	of 2						