

FOR ALIGNMENTS OR ORIENTATIONS OTHER THAN 90°, THE SPECIFIC ORIENTATION MUST BE APPROVED BY THE DELAWARE COUNTY ENGINEER'S OFFICE.

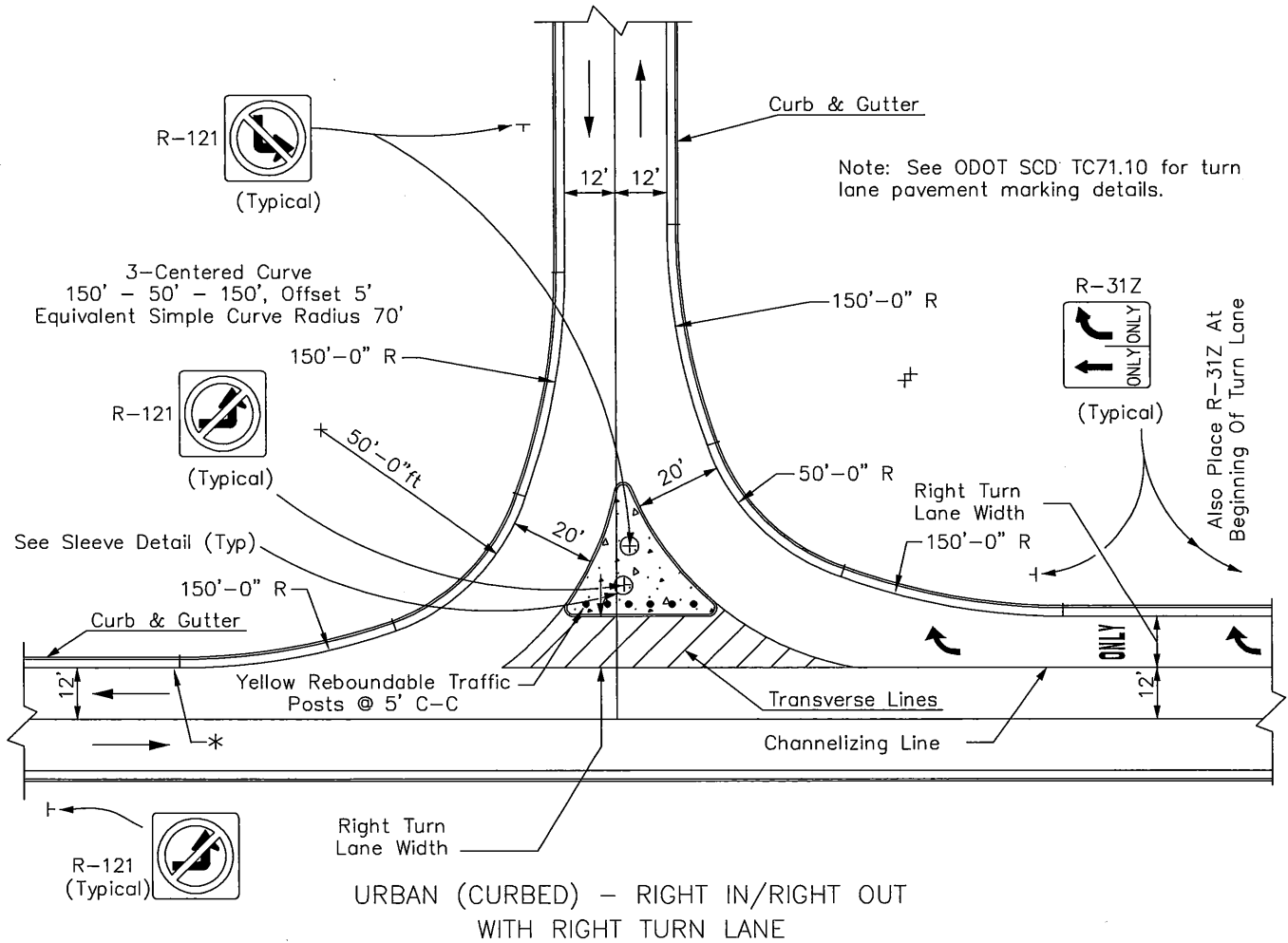
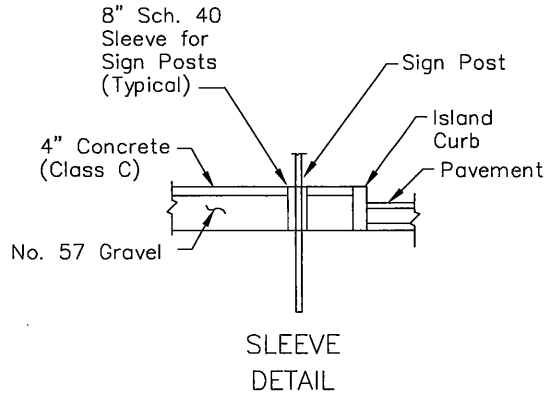
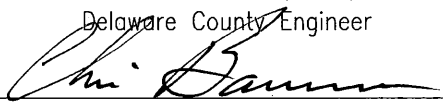

Note: See ODOT SCD TC71.10 for turn lane pavement marking details.

\* ON EXISTING CURBED ROADS, SAWCUT AND REMOVE PORTION OF EXISTING CURB AND GUTTER AS NECESSARY TO PROVIDE A SMOOTH TRANSITION FROM THE PROPOSED DRIVE CURB TIE-IN INTO THE EXISTING CURB AND GUTTER.

<p>CHRIS E. BAUSERMAN, P.E., P.S. Delaware County Engineer</p>  <p>Delaware County Engineer</p>	<p>STANDARD CONSTRUCTION DRAWING</p> <p>RIGHT IN/RIGHT OUT WITH RIGHT TURN LANE</p>	<p>DELAWARE COUNTY ENGINEER'S OFFICE 50 Channing Street Delaware, Ohio 43015 PHONE: (740)833-2400 FAX: (740)833-2399 www.co.delaware.oh.us</p>									
<p>APPROVED 1-04-2010</p>	<p>REVISED</p>	<table border="1"> <tr> <td>Drawn</td> <td>EM</td> <td>sheet</td> <td>1</td> <td rowspan="2">FILE NO. DCED-R2451A</td> </tr> <tr> <td>Checked</td> <td>EM</td> <td>of</td> <td>2</td> </tr> </table>	Drawn	EM	sheet	1	FILE NO. DCED-R2451A	Checked	EM	of	2
Drawn	EM	sheet	1	FILE NO. DCED-R2451A							
Checked	EM	of	2								