

BOTTOM VIEW OF COVER
(SEE SHEET 2 OF 2
FOR ALTERNATE DESIGN)

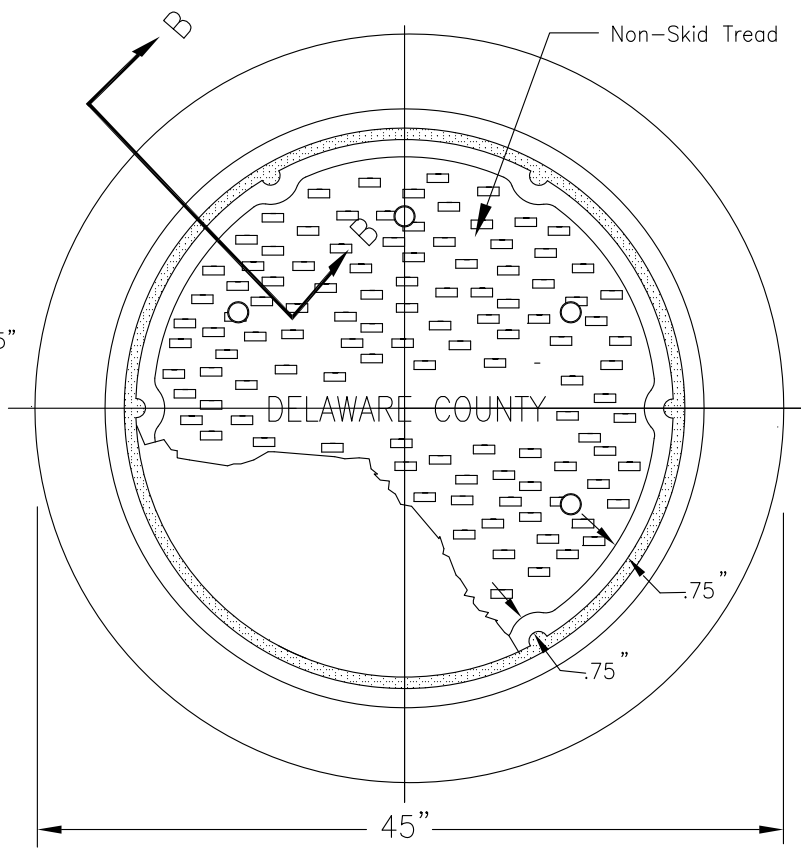

TOP VIEW OF ASSEMBLY

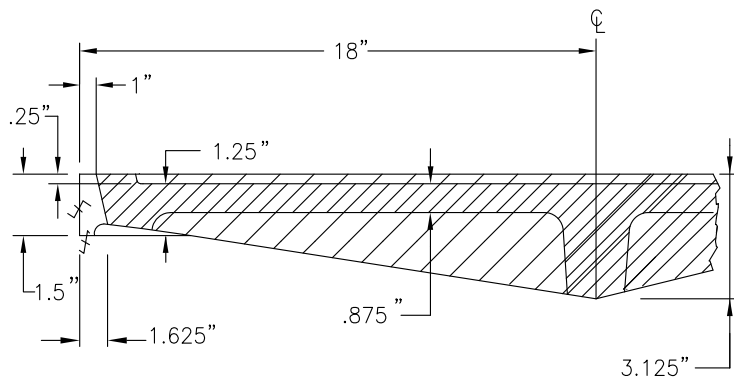

SECTION A-A

Total Weight=720 lbs.

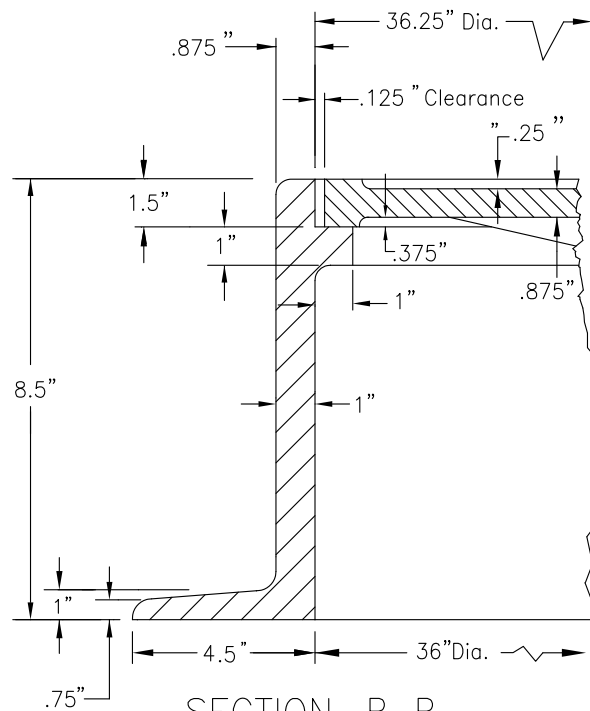

SECTION B-B

NOTE:

Dimensions shown are equivalent decimals of 1/8 inch fractional sizes. Tolerances shall be accepted foundry standards as outlined in the Iron Castings Handbook published by the American Cast Metals Institute. Frames, grates, and covers shall meet the requirements of 604.02.

CHRIS E. BAUSERMAN, P.E., P.S.
Delaware County Engineer

Delaware County Engineer

APPROVED
1-22-2008

REVISED
1-04-2010

STANDARD DIMENSIONS FOR
36" MANHOLE
FRAME & COVER CASTINGS
(STORM SEWER)

DELAWARE COUNTY ENGINEER'S OFFICE
50 Channing Street
Delaware, Ohio 43015
PHONE: (740)833-2400 FAX: (740)833-2399
www.co.delaware.oh.us

Drawn KS
Checked EM

sheet 1
of 2

FILE NO.
DCED-S114A