

ALUMINUM STEP
Item 711.30

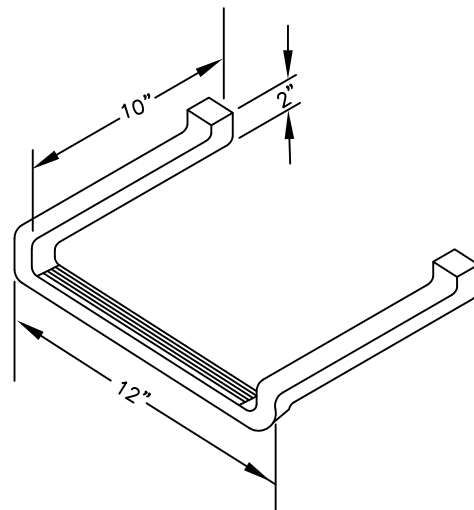

FERROUS METAL STEP
Item 711.13

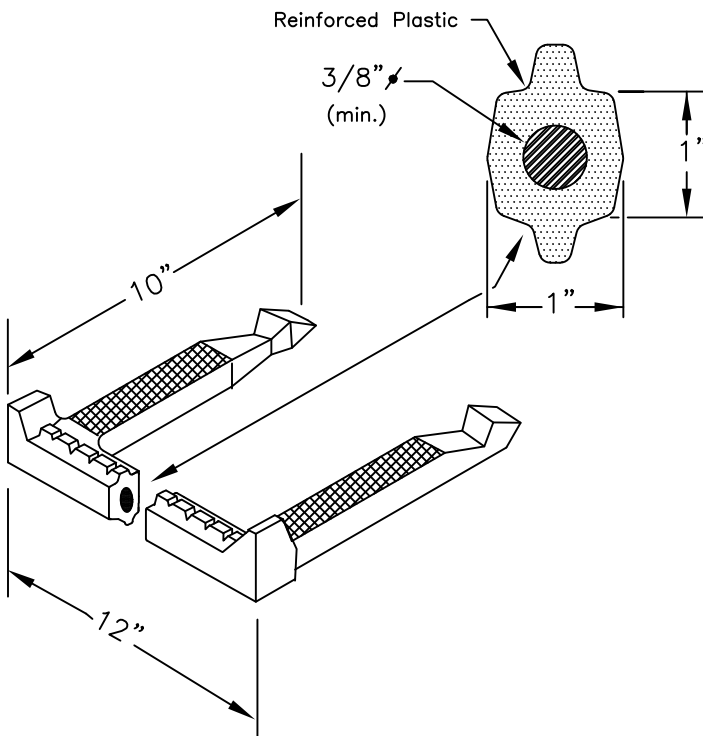

POLYPROPYLENE STEP
Item 711.31

NOTES:

1. STEPS SHALL MEET THE REQUIREMENTS OF ASTM C-478, AND SHALL BE INSTALLED WITH A UNIFORM VERTICAL SPACING OF 12" TO 16".
2. STEPS SHALL HAVE A MINIMUM CROSS SECTIONAL DIMENSION OF 1" FOR FERROUS METAL AND 3/4" FOR ALUMINUM.

CHRIS E. BAUSERMAN, P.E., P.S.
Delaware County Engineer

Delaware County Engineer

APPROVED
1-22-2008

REVISED
1-04-2010

STANDARD CONSTRUCTION DRAWING

MANHOLE
STEPS
DETAIL

DELAWARE COUNTY ENGINEER'S OFFICE

50 Channing Street
Delaware, Ohio 43015

PHONE: (740)833-2400 FAX: (740)833-2399

www.co.delaware.oh.us

Drawn KS
Checked EM

sheet 1
of 1

FILE NO.
DCED-S119