

DELAWARE COUNTY ENGINEER	
DRAWING NO. LIGHT POLE DETAIL REV. #1	REV. DATE 04/26/16

STANDARD CONSTRUCTION DRAWING  
 LIGHT POLE  
 ALUMINUM ALLOY  
 POWDER PAINT - BLACK

SHEET NO.  
1 OF 2

CHRIS E. BAUSERMAN, P.E., P.S.  
 DELAWARE COUNTY ENGINEER  
 50 CHANNING STREET  
 DELAWARE, OHIO 43015  
 PHONE: (740)833-2400 FAX:(740)833-2399  
 WWW.DELAWARECOUNTYENGINEER.ORG

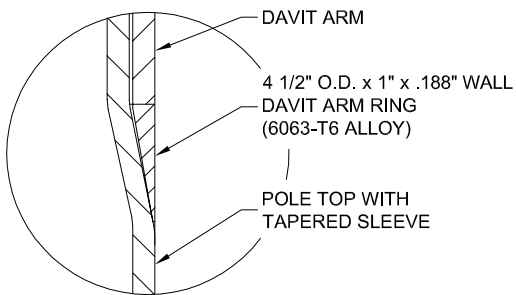
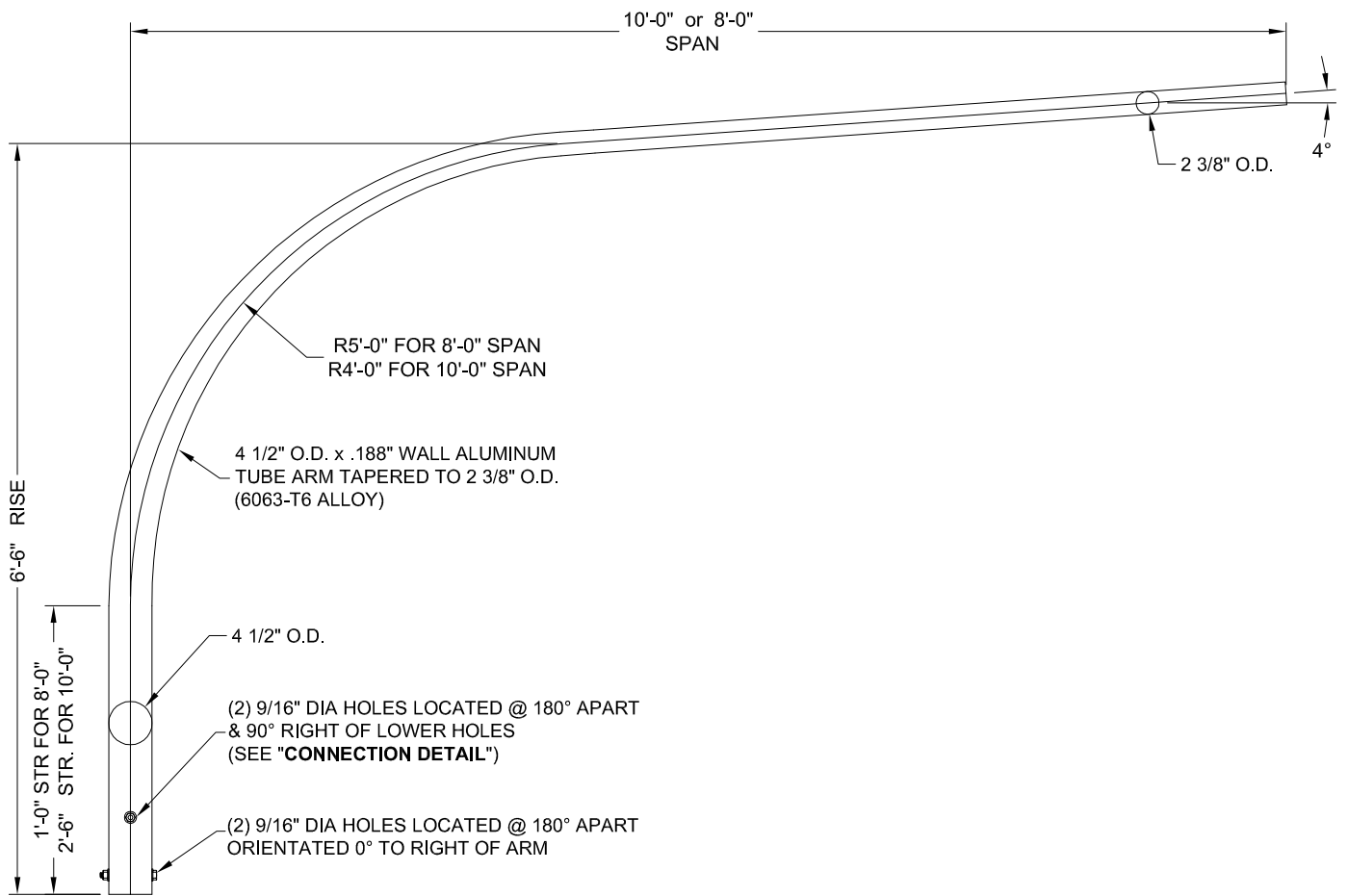

**DETAIL A**

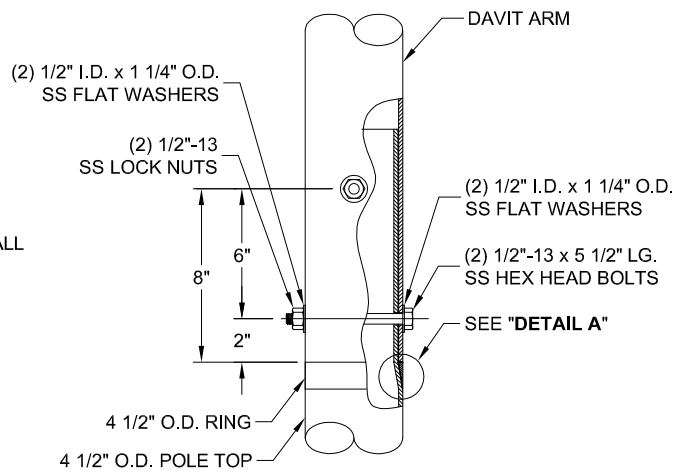

**CONNECTION DETAIL**

DELAWARE COUNTY ENGINEER

DRAWING NO.  
LIGHT POLE DETAIL REV. #1

REV. DATE  
04/26/16

STANDARD CONSTRUCTION DRAWING  
DAVIT ARM  
ALUMINUM ALLOY  
POWDER PAINT - BLACK

SHEET NO.  
2 OF 2

CHRIS E. BAUSERMAN, P.E., P.S.  
DELAWARE COUNTY ENGINEER  
50 CHANNING STREET  
DELAWARE, OHIO 43015  
PHONE: (740)833-2400 FAX:(740)833-2399  
WWW.DELAWARECOUNTYENGINEER.ORG